



## Permeate Pump Installation Instructions

1. Inspect **Permeate Pump** (Figure 1). Be sure you have all parts. i.e. Stem kit with 4 stems (each stem has 2 O-rings) and 8 screws.  
Inspect **Optional** items, i.e. 4 fittings, Permeate Mounting Clip Kit, and Retrofit Kit. Remove the plugs from the 4 ports and be sure there is no foreign material in the ports.
2. Wet the O-ring on the 4 stems and insert into the 4 ports of the pump. Secure the stems using two screws for each fitting. If you have ordered John Guest fittings (optional), firmly attach the 4 fittings to the 4 stems. Be sure each stem bottoms out in the Guest fitting.
3. **Mounting of Permeate Pump:** Two methods are commonly used. If you ordered Part Number 25-021 Permeate Mounting Clip Kit, (includes clip and 2 #10 x 3/4" self tapping screws) mount the clip on the systems bracket or other suitable location using the two screws provided. Also available, upon factory request, is a retrofit kit consisting of a membrane housing clip with nut and screw (Figure 3). Drill a #10 hole in the center of the base of the Permeate Pump Mounting Clip and join the two clips (Permeate Pump and membrane housing) at their bases using the screw and nut provided. The Permeate Pump mounts onto the R.O. membrane housing using the clip assembly.
4. The label clearly show the location of each port. Mount the Permeate Pump with Outlets (both brine and permeate) **Positioned Up**. This step is **VERY IMPORTANT** to rid any entrapped air.
5. Shut off feed water and turn off product tank valve. Bleed residual pressure by opening the faucet.
6. Locate the "**BRINE TO DRAIN**" tube. it is extremely important that the flow restrictor is in front of (before) the "brine inlet" to the **Permeate Pump**. The pump **will not operate** if the restrictor is in the "**BRINE OUT**" line leading to the drain.
  - a. If you cut the tube, be sure the cut is after the flow restrictor. Insert tube firmly **into "BRINE IN"** fitting on the **Permeate Pump**. Be sure tube bottoms out in the fitting.
  - b. Connect a new length (long enough to reach the air gap drain) of tubing to the "**BRINE OUT**" fitting on the **Permeate Pump**. Be sure tube bottoms out in the fitting. This tube connects directly to the air gap drain.
7. Locate the product water (permeate) tube exiting (after) the membrane leading to the inlet side of the hydraulic shut-off valve. The outlet tube from the hydraulic shut-off valve leads to the TEE on the inlet side of the post-filter which leads to the product water tank and the product delivery faucet as shown in Figure 4.
  - a. Disconnect the tube from the inlet side of the hydraulic shut-off valve and connect the tube to the "**PERMEATE IN**" fitting on the **Permeate Pump**. Be sure the tube bottoms out on the fitting.
  - b. Connect a new tube from the "**PERMEATE OUT**" fitting on the **Permeate Pump** to the inlet side of the hydraulic shut-off valve as shown in Figure 5. Be sure the tube bottoms out on the fitting. If it is desired not to use the hydraulic shut-off valve, connect the permeate pump as shown in Figure 6 (see installation notes).
8. Turn on feed water supply and open product tank valve. The **Permeate Pump** should begin cycling. An audible clicking sound will be heard as the pump operates. Be sure to point this out to your customer so that he understands that this is normal This will avoid a service call later.

**Important:** If pump is not cycling (clicking), make sure all connections are made correctly and that all entrapped air has been bled from the lines by just cracking open the faucet.

**Note:** The attached specification sheet shows a typical R.O. system diagram for reference. If you want to retrofit another type of R.O. unit (a manifold type) or if your system has another configuration of hydraulic shut-off valve, or if you are using an electric booster pump, consult factory for instruction.

## Technical Specifications (dimensions are in inches)

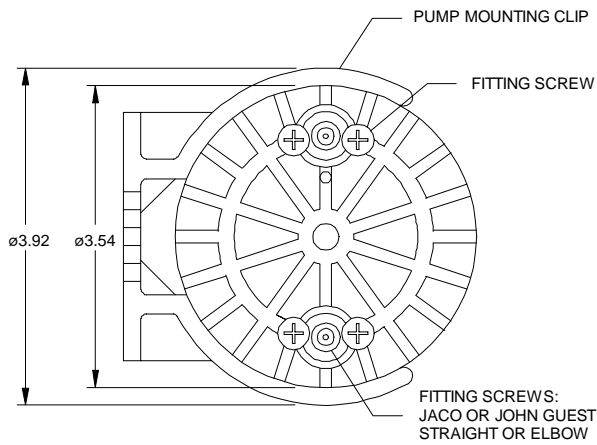
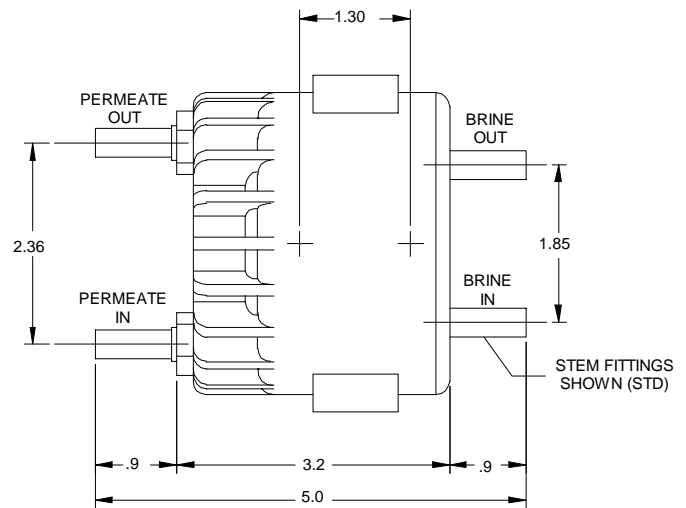

FIGURE 1. PERMEATE PUMP DIMENSIONS



### Installation Notes

As shown in Figure 6, the hydraulic shut off valve may be removed from the system and the Permeate Pump will operate as the shut off valve. This configuration may be used only if a substantial volume of water is drawn from the tank each time. The benefit is that the system will produce more water than with the shut off valve installed. If however, the amount of water withdrawn is small (a cup at a time), it is recommended that the hydraulic shut off valve be retained as shown in Figure 5. This will reduce TDS creep of the RO membrane. The addition of the Permeate Pump decreases the time to fill the tank, but it does not reduce the amount of water produced. For manifold type RO systems, contact the factory for installation recommendations.

### Technical Specifications

**Part number:** ERP 1000

**Pump Type:** Positive displacement, reciprocating, single action diaphragm, hydraulically driven

**Weight:** 1 lb.

**Materials:** Wetted Materials: NSF listed and FDA approved thermoplastic; EPDM

**Fittings:** Optional JACO® or John Guest® straight or elbow quick disconnect (Figure 2)

**Mounting:** Always mount with outlet ports up. Mounting clip (ABS) with (2) #10 S.S. screws available

**Retrofit Mounting:** Order membrane clip if required (Figure 3). Base of Membrane clip attaches to base of Permeate Pump clip with supplied fastener. Permeate Pump can then be mounted to membrane with clip assembly as shown in Figures 5 & 6.

**Hydraulic:** Maximum Pressure - 100 psi brine and 100 psi permeate side

**Environmental:** 0 - 100% humidity, 32 - 140 degrees F ambient; water temp, 32 - 140 degrees F

**Warranty:** 2 years

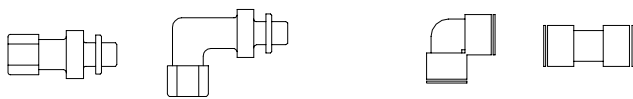

FIGURE 2. JACO® AND JOHN GUEST® ELBOW AND STRAIGHT FITTINGS

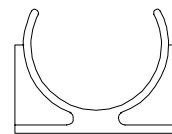

FIGURE 3. MEMBRANE CLIP

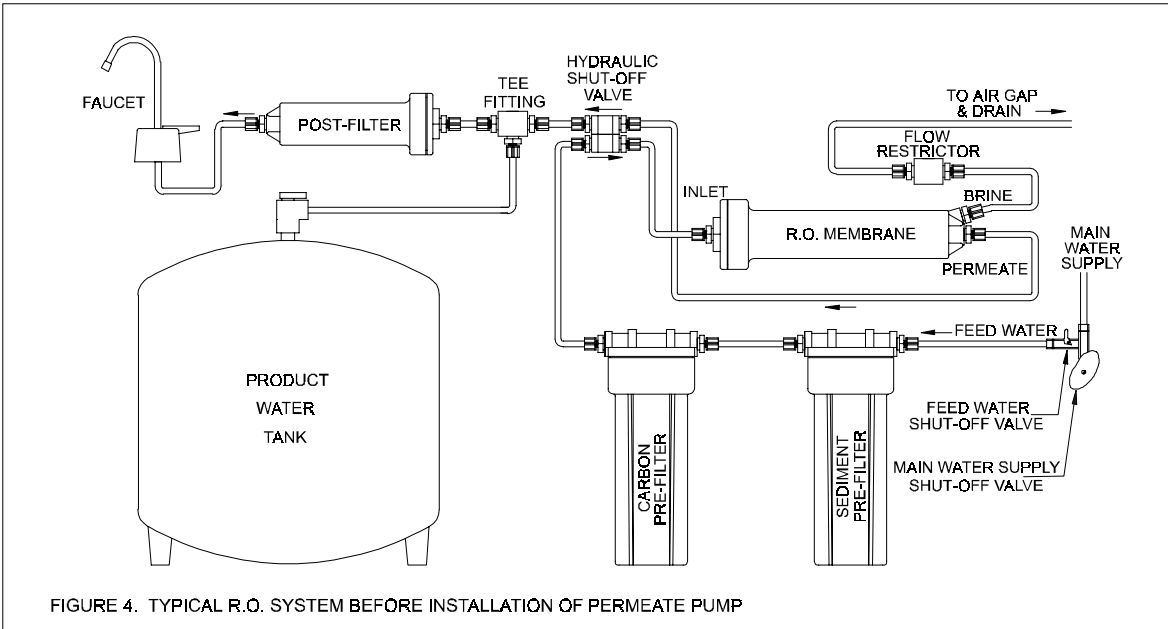

FIGURE 4. TYPICAL R.O. SYSTEM BEFORE INSTALLATION OF PERMEATE PUMP

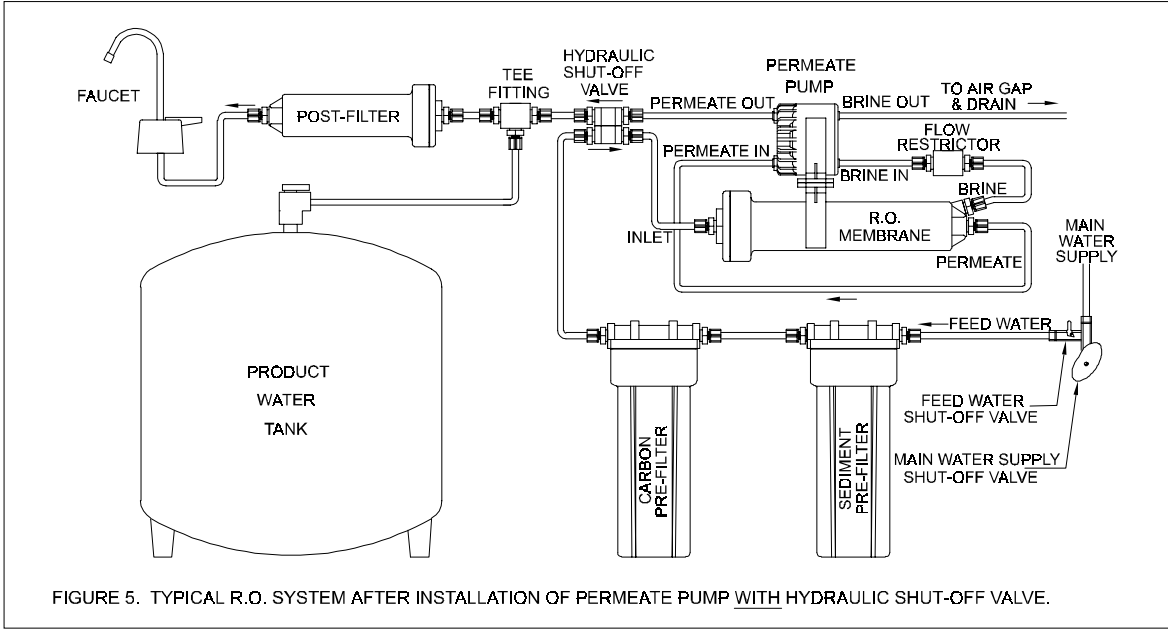

FIGURE 5. TYPICAL R.O. SYSTEM AFTER INSTALLATION OF PERMEATE PUMP WITH HYDRAULIC SHUT-OFF VALVE.

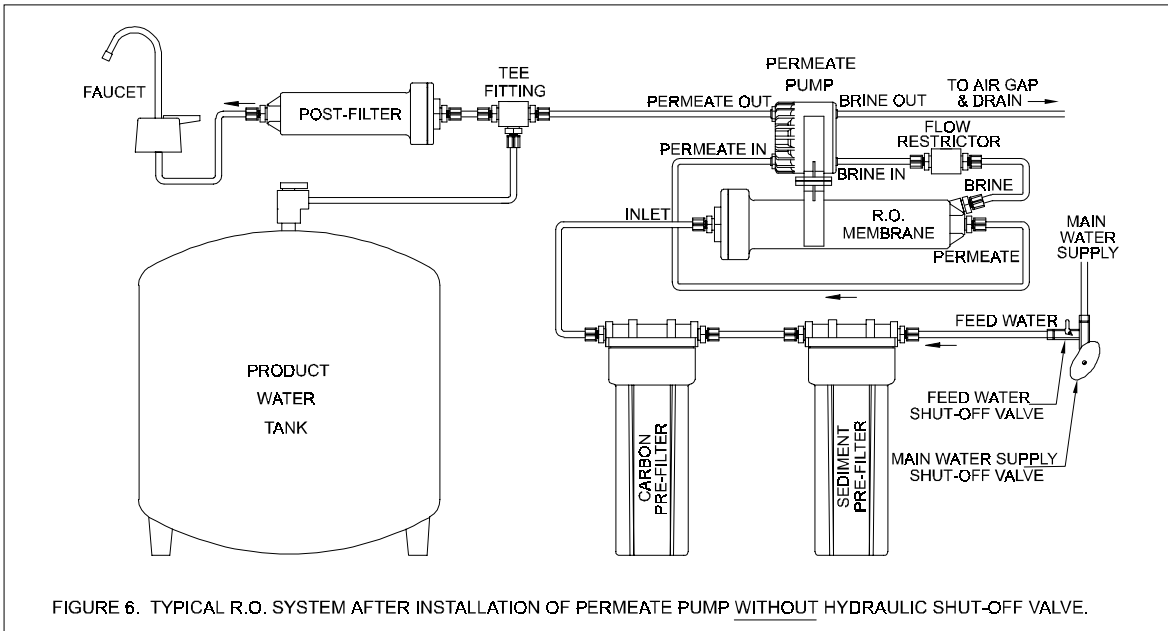

FIGURE 6. TYPICAL R.O. SYSTEM AFTER INSTALLATION OF PERMEATE PUMP WITHOUT HYDRAULIC SHUT-OFF VALVE.